

Flexible containers

The flexible solution for clean and fast product discharge

Particularly problematic bulk goods or bridging materials often get stuck in weighing or product containers. *ROWEFLEX*® Flexible containers are moved by vibration elements or knockers and their special shape allows a quick and gentle product discharge without residue.

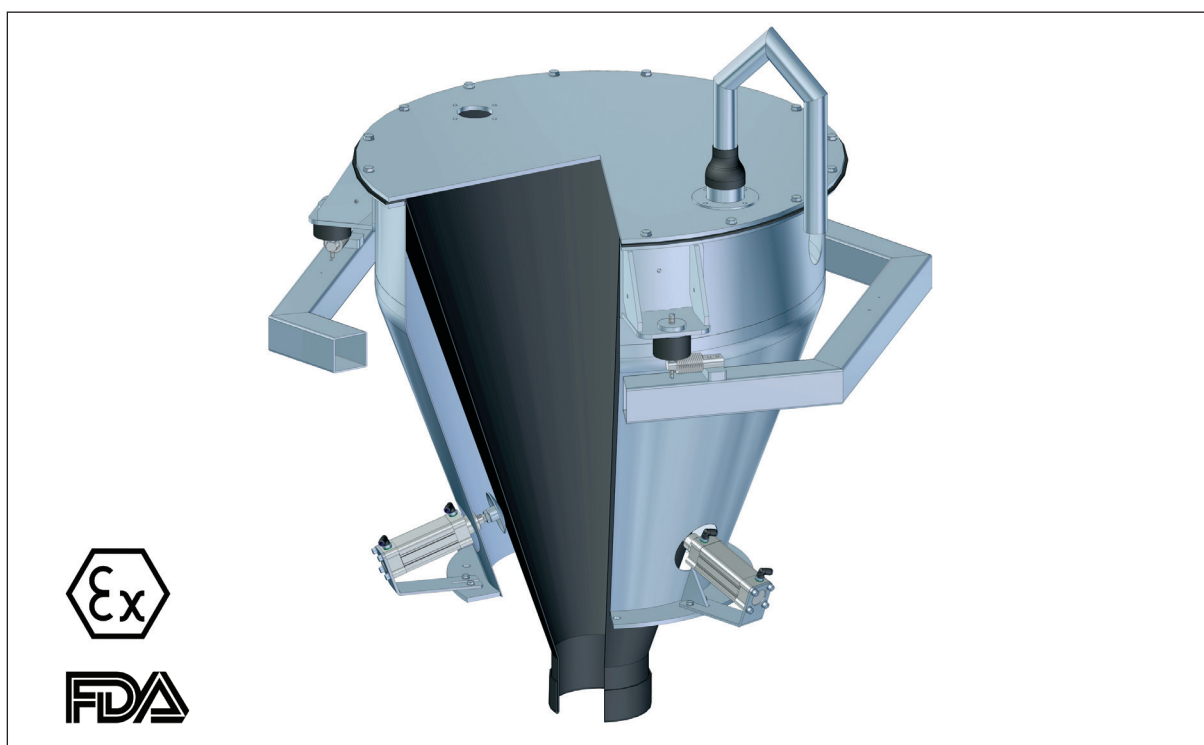


Figure: Flexible container lining in a weighing container

Advantages

of the *ROWEFLEX*® flexible containers:

- Retrofitting option for existing containers
- Low-noise and effective use of knockers
- Faster discharge of problematic products with less residue
- Simple discharge, also with unfavourable wall inclines
- Self-cleaning due to flexibility
- Available in ATEX version
- FDA-compliant version available

Applications

for the *ROWEFLEX*® flexible containers:

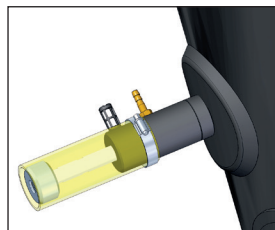
- Food products
- Feed products
- Pharmaceuticals
- Carbon black and tyres
- PVC processing
- Toxic media
- Colour pigment production
- Colour pigment processing

ROWEFLEX® flexible containers

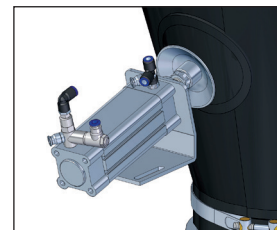


Figure: ROWEFLEX® Flexible containers in EPDM black, FDA-compatible, antistatic

Sample view of discharge aids



Funnel vibrator



Funnel knocker

Sample view of additional elements



Funnel filling level sensor



Funnel flange

ROWEFLEX® Flexible containers are specifically custom-made for your application:

Special features

ROWEFLEX® Flexible containers are delivered ready for connection:

- All profiles and shapes are possible
- This special method of customisation does not create mould costs
- Particular design and production
- Consulting and installation on site
- Fabric reinforcements for tension and pressure strain relief are possible for many materials

Extract from material portfolio

Standard elastomer quality of the ROWEFLEX® container lining:

ROWEFLEX® Material	Description	Colour	FDA-comp.	Electr. cond.
NK	Natural rubber	Beige	-	-
NK w	Natural rubber	White	+	-
PG	Natural rubber	Grey	-	-
CR w	Chloroprene rubber	White	+	-
CR sw	Chloroprene rubber	Black	-	+
EP sw	EPDM rubber	Black	+	+
EP w	EPDM rubber	White	+	-
NBR sw	Nitrile rubber	Black	-	+
NBR w	Nitrile rubber	White	+	-
SI	Silicone rubber	Light	+	-

We will gladly advise you with regard to the selection of the correct ROWEFLEX® material to ensure that your products are optimally discharged.

We recommend to use the ROWEFLEX® Flexible containers in combination with ROWEFLEX® Pinch valves as shut-off device and ROWEFLEX® 2-way diverter for distribution processes.